



Granary



■ DESIGN GUIDELINES
JULY 2024

Granary Metropolitan District



TABLE OF CONTENTS:

1.0	INTRODUCTION	4
1.1	Purpose of these Guidelines	
1.2	Community Vision	
1.3	Relationship to Other Plans and Criteria	
1.4	Architectural Review Committee	
2.0	LAND USE	7
2.1	Land Use Plan	
3.0	ARCHITECTURAL CHARACTER	8
3.1	General Character & Product Types	
3.1.1	Traditional Single Family	
3.2	Typical Improvements	
3.3	Architectural Review Committee Procedures	
4.0	LANDSCAPE STANDARDS	20
4.1	Public / Open Space Landscape	
4.2	Private Landscapes	
4.2.1	General Landscape Requirements	
4.2.2	Landscape Guidelines	
4.2.3	Xeriscape Requirements	
4.2.4	Synthetic / Artificial Turf Requirements	
4.3	Landscape Lot Typicals, Maintenance, & Required Planting	
4.3.1	Single Family Detached Front and Side Load	
4.3.2	Single Family Detached Front Load/Pass-By	
4.4	The Granary Signature Plant List	
5.0	FENCING	33
5.1	Permitted Fencing	
5.1.1	3-Rail Fence	
5.2	Fencing Setbacks	
5.3	Fencing Standards	
6.0	DEVELOPMENT AND BUILDER SIGNAGE	39
6.1	Sign Locations	
6.2	Builder Signage	
6.3	Builder Sign - On Site & Model Home	
6.4	Builder Directional Sign	

1.0 INTRODUCTION:

1.1 PURPOSE

These Design Guidelines are established to ensure the overall development quality is maintained during the final planning and design of Granary, and maintained after design and construction. They are intended to promote design excellence by encouraging builders to explore and expand their range of architectural styles and methods when building residential products. These guidelines are intended to promote creativity and incorporate the flexibility necessary to achieve the diverse, yet cohesive community planned for Granary. Creativity and excellence in design will be the primary criteria for receiving approvals during the architectural review process. The intent of these guidelines is not to provide prescriptive “standards” or “requirements” that will only impair the architect/builder from being able to achieve the high level of design desired for this community. Rather, these guidelines are meant to encourage excellence in design and are not intended to be interpreted as strict requirements.

1.2 COMMUNITY VISION

Granary is a new master-planned community incorporating a range of uses including but not limited to residential, trails, and a variety of parks and open spaces. One of the foundational ideas behind the Granary plan is traditional residential housing set within a dynamic, walkable neighborhood. Characterized by front porches, a variety of pocket parks and gathering spaces. The design of Granary is intended to allow for serendipitous encounters that will foster individual relationships and a closer community.

To help make the community vision a reality, land use standards are in place to create a compact, walkable community. Modified roadway standards in Granary serve to efficiently accommodate the integration of residential lot types, sidewalks, trees lawns, vehicles, pedestrians, and bicyclists.

Residential development anticipated at Granary includes traditional front-loaded single-family lots.

1.3 RELATIONSHIP TO OTHER PLANS AND CRITERIA

These Design Guidelines serve as the basis for guiding each builder's proposal for architectural design of the structures and other lot improvements and ensuring conformance with the overall intent of the Granary master planned community.

These guidelines do not modify other applicable Federal, State, and Local codes and ordinances, but should be used in conjunction with these regulations. Use of property and improvements to property must comply with applicable building codes and other governmental requirements and regulations. Additional standards pertaining to development within Granary can be found in the approved Overall Development Plan (ODP), reception no. 4735961.

1.4 DESIGN REVIEW COMMITTEE

All new development within Granary is subject to review by the Architectural Review Committee (ARC) for conformance with these Design Guidelines as well as those set forth in the Master Declaration of Covenants, Conditions, and Restrictions (CC&R's) for the Granary Metropolitan District. Homeowners and Developers are strongly encouraged to meet with the ARC early in the design process to ensure conformance with Granary theming.

The review process will consist of the following:

- Submit plans to architectural review committee
- Committee review
- Comments received
- Plan adjustments
- Approval/denial

For a more detailed look at the ARC design review process refer to Article 2 of the Declaration of Covenants, Conditions, and Restrictions of Granary (CC&R's).

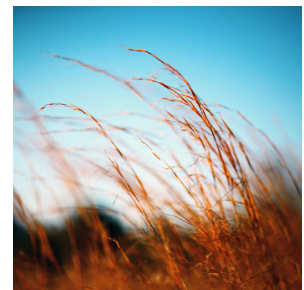



2.0 LAND USE:

2.1 LAND USE PLAN



Note: Image is conceptual and shown for illustrative purposes only. Land Use Plan is subject to change.

The Land Use Plan shows the conceptual design for Granary, including the general arrangement of various housing types. Granary includes traditional single family detached front-loaded homes on lots of varying sizes. The neighborhood plan will include several parks, to be designed, built, and maintained by the District.

3.0 ARCHITECTURAL CHARACTER:

3.1 GENERAL CHARACTER & PRODUCT TYPES

Architectural styles shall be Colorado vernacular, possibly including but not limited to Craftsman, Prairie, and Farmhouse (this includes contemporary versions of the previous styles). Present day interpretations of traditional styles are encouraged. Homes should be different than, but compatible with, the neighboring homes. Duplicate floor plans, elevations, or color schemes shall not be allowed on adjacent lots or on lots across the street from each other. Building mass should provide interest and depth.

**The photos shown below are for illustrative purposes only and do not necessarily reflect the final design of the homes at Granary.*

3.1.1 TRADITIONAL SINGLE FAMILY

1. Detached Single Family Lots

- a. A minimum of 5 home floor plans/styles shall be available within the development. No one floorplan/style may comprise more than 35% of all homes. These can be modified to meet the below requirements.
- b. Similar house elevations shall not be placed on immediately adjacent lots, which is defined as next to each other or directly across the street (sharing 30% or more of street frontage).
- c. Adjacent elevations shall have at least two distinguishing characteristics. These may include differences in exterior materials, changes in roof lines, and garage placement/orientation.
- d. Identical and/or mirrored floor plans are not permitted on immediately adjacent lots.
- e. Model homes shall be allowed within the ODP in the discretion of the developer; however, the architectural provisions of this ODP shall apply equally to all such model homes. Developer shall be allowed model home(s) provided there is initial acceptance of subdivision improvements in the area of the model homes that will allow access to and of operation of said home(s). A maximum of one (1) of each model will be permitted.
- f. Sheds less than 120 sf shall be allowed on single-family lots.
- g. Minor cosmetic changes such as different paint color, reversing or creating mirror images of the exterior architectural elevations, shutters, decorative brackets, or using different brick or stone color shall not meet the intent of defining a different elevation.

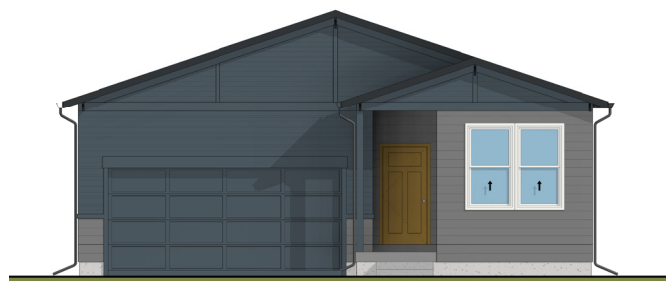

2. Materials:
 - a. Acceptable materials include vinyl, cementitious hardboard siding and shingles, stained cedar shingles, painted wood siding, and stucco. Brick and stone (including faux stone) are encouraged but not required.
 - b. Siding patterns may include clapboard, shiplap, drop siding, tongue-and-groove (vertical or horizontal), board and batten, and shingle coursing.
 - c. Exposed foundations exceeding eight-inch height on the front elevation are not permitted.
3. Building orientation: The primary pedestrian entry and windows shall face a street.
4. Front porches: Homes shall include a covered front porch associated with the entry, or other suitable covered architectural feature to accentuate the entry to the home.
5. Roofs: The maximum length of a continuous street facing roof ridge is 40 feet, unless the roof is punctuated by dormers or intersections with perpendicular roof systems.
6. Garages:
 - a. The dwelling units on a block face shall have recessed garages that are a minimum of 4 feet behind either the living area of the home or the front of a covered porch.
 - b. Three-car garages, if proposed, shall be:
 - i. Third garage shall be recessed by at least two additional feet from the two-car garage plane; or,
 - ii. Separated by a two-foot width masonry column from the two-car garage; or,
 - iii. Tandem configuration

3.2 TYPICAL IMPROVEMENTS

The following list contains a wide variety of typical types of improvements which homeowners frequently consider installing. Unless otherwise specifically stated, drawings and/or plans for a proposed improvement must be submitted to the ARC and written approval of the ARC obtained PRIOR TO commencement of construction of the improvement. If a proposed improvement is not specifically listed below, the homeowner, architect, builder, or landscape designer must make a request to the ARC for review and approval. Please ensure the most current revision of the guidelines are being used, as they can change from time to time as allowed by Granary Conditions, Covenants, and Restrictions (CC&R's). Please contact the District Manager for the most current version of the Design Guidelines and CC&R's. Submittal fees may be adjusted from time to time by the ARC. ARC approval is required for, but is not limited to, the following typical improvements:

ADDITIONS and EXPANSIONS

An addition or expansion of the home is an increase in the size of a building brought about by constructing additional usable building space to the side(s) or top of an existing structure. Examples include room additions, pop-tops, 3 or 4 season enclosed patios or attached garages. All additions and expansion must be approved by the ARC and meet the following guidelines.

- Shall match or closely compliment the materials and colors used on the home.
- Must be constructed entirely within allowable building setbacks as established by the Town.

ANTENNA/SATELLITE DISHES

Satellite Dishes or Antennas that do not require ARC approval:

- An antenna designed to receive direct broadcast satellite services, including direct-to-home satellite services, that are one meter (39 inches) or less in diameter.
- An antenna designed to receive video programming services via multipoint distribution services, including multi-channel multipoint distribution services, instructional television fixed services, and local multipoint distribution services, that is one meter (39 inches) or less in diameter or diagonal measurement; or
- An antenna that is designed to receive television broadcast signals.

The District does ask that owners try to keep such dish or antenna and related cables contained within the structure or otherwise screened from public view to the extent feasible, so long as such placement does not substantially degrade the reception of the signal. If the dish, antenna or the cables cannot be screened from public view, the cables in public view need to be painted the same color as the home. Satellite dishes and antennas must comply with Colorado Law.

ARBOR / PERGOLA

An arbor is a free-standing arch and a pergola is a feature with an open lattice that may or may not be attached to the building, which both provide shade and/or aesthetic feature with or without climbing plants. Occasionally, a temporary seasonal fabric cover may be incorporated in the pergola – see guidelines for TEMPORARY SHADE COVER. An arbor or pergola can be permitted subject to

approval by the ARC which meets these guidelines:

- Constructed on the individual property at a max height of ten (10) feet.
- Compliments the house color and materials, is treated to prevent weathering, and arbor/pergola shall be stained or painted.

ARTIFICIAL TURF- See Landscape Requirements and Guidelines.

AWNINGS OR EXTERIOR SHADES

An awning is a roof like shelter extending above a window, door, deck, or patio and is commonly made of canvas or a similar durable material. Exterior shades look and feel like interior shades but are used on patios or decks to shade in peak sun times of the day. Awnings or exterior shade structures are permitted on homes for environmental purposes. ARC approval is required PRIOR TO installation and the awning or exterior shade needs to adhere to the following guidelines:

- Professionally installed,
- Color that compliments the home,
- Height shall not exceed 10 feet over patio or deck, and
- Retractable.

BARBECUE/GAS GRILLS

Barbecue grills, smokers, etc. shall be maintained in the rear yard of the home. Any applicable governmental fire/smoke bans shall be adhered to.

BASKETBALL HOOPS/OTHER PORTABLE PLAY EQUIPMENT

Basketball hoops and other portable play equipment to include but not limited to tether ball and soccer nets are prohibited on streets, sidewalks, and alleys due to safety issues.

PORTABLE HOOPS:

Approval is not required provided the following guidelines are met: Hoops must be mechanically sound, clean, and well maintained. For safety and access reasons, hoops may only be used in the owner’s backyard or on the owner’s driveway and placed so that play does not extend onto neighbors’ properties, or community sidewalks and streets. The base must be fully filled when the portable hoop is in use. Portable hoops and other temporary play equipment should be stored out of sight of the street and during extreme weather events. Only one portable basketball hoop is permitted per lot.

- No items that are not part of the basketball hoop may be used to keep the hoop upright (sandbags, blocks, etc.), except for Hoop Secure or similar. Please check with the ARC for further clarifications on exceptions.
- The owner is responsible to ensure the basketball hoop is always aesthetically pleasing. Should the hoop be in disrepair, knocked over, broken, or have any unsightly condition the District may require immediate removal.
- The basketball post must either be black in color or match the color scheme of the home.
- Backboard must be clear in color.

BACKYARD OR IN-GROUND HOOPS:

ARC approval is required prior to installation. All requests will be evaluated on placement and circumstances of each backyard, as well as court area surface, visual screening, and proximity to neighbors.

All other play equipment must be submitted to the ARC for approval. i.e. play structures, trampolines, etc.

BLOCKAGE OF EXISTING SOLAR PANELS

No homeowner can erect an object or construct an improvement that will obstruct access to sunlight for existing solar panels within the community without the written permission from the owner of the property with the solar panels. A copy of this written permission from the owner of the property with the solar panels must accompany the Architectural Review Submittal for approval.

CARPORTS

Carports are not permitted in the community.

CHIMINEAS/FIRE PITS/OUTDOOR FIREPLACES

Approval is required for all permanent installations. Gas-fired pits are recommended, and applicable governmental permits must be obtained prior to installation. In all cases these items shall not create a nuisance. All applicable governmental fire/smoke bans shall be adhered.

CLOTHES LINES

Retractable clotheslines are permitted. They shall be located on the rear of the home and shall remain retracted unless in use. Retractable clotheslines may not be mounted or attached to lot fencing.

COMPOST

Compost containers must not be immediately visible to adjacent properties and odor must be controlled. Underground composting is not permitted.

COOLING OR HEATING APPARATUS

Per Declaration, Article 3.5.3, no types of refrigerating, cooling, or heating apparatus shall be permitted on a roof or hung on exterior walls or outside of windows, except for residential solar systems. Window units are not permitted in the community. Conventional air conditioning units located on the ground of a Lot are permissible when approved by the ARC.

DECK/BALCONY/PORCH

ARC approval is necessary on all deck, balcony or porch additions and enclosures or permanent overhangs on an existing deck/balcony/porch. Deck, balcony, or porches must be constructed entirely within allowable building envelopes as established by the Town and complement the colors and materials of the home. Decks cannot be higher than ten (10) feet above grade and the support posts for elevated decks on walkout lots must have a minimum size of 6x6 and be integrated with the architecture and structure of the home.

DECK/BALCONY/PATIO - RAILINGS

To prevent access through the railings on your deck, balcony, or patio, you may install a 2" x 2" or 2" x 4" welded wire mesh attached to the inside of the front, back or side railings without prior ARC approval. All other materials must be approved by the ARC.

DOG RUN/DOG HOUSE

Per the Declaration, Article 3.5.2, Dog runs must be made of the same material as the approved fencing and must be approved by the ARC. No dog runs shall be visible from a street or from the ground level of any Lot, variances can be granted by the ARC on a case by case basis. One pet enclosure is allowed for each Lot and cannot exceed 100 square feet. All dog runs must be located in the rear or side yard. Dog runs shall not be located within five (5) feet from any property line and

shall be screened by approved materials and landscaping so that the dog therein is not visible from neighboring Lots and/or common areas.

Dog houses must be painted to match the exterior of the house body and trim colors. One dog house is permitted per lot and shall not be visible above the fence or from the front of the house.

Dog Runs/Dog Houses must always be maintained to include timely cleanup/removal of dog waste and elimination of odors.

DOORS

Replacement of an existing door with the same previously approved door does not require ARC approval. Replacement of an existing door with a new type of door or color requires ARC approval. No prior ARC approval is needed for an all season, storm or security door, if it matches the trim of the individual home.

DRIVEWAYS

Approval is required for any changes or alterations to the existing driveway. Any proposed driveway expansions shall not be permitted to promote the parking or storage of any vehicle in the front or side yard area. Driveway additions/alterations must not violate municipal/building code.

ENERGY DEVICES

- Solar Panels - Please see guidelines for SOLAR PV SYSTEMS. Non-glare or non-reflective finishes are preferred. The owner shall be responsible for deterring animals from nesting in, around or under roof mounted panels.
- Electric Automobile Charges - Must be located within the house or garage.
- Generators - Approval is required for all types of stand-by power generators. Screening may be required.
- Wind Generators are not permitted, per the Declaration, Article 3.6.3.

EXTERIOR LIGHTS

Per the Declaration, Article 3.10, any exterior lighting installed or maintained on the Lots shall either be indirect or of such controlled focus and intensity so as not to disturb the residents of adjacent or nearby property. No light shall be emitted from any Lot that is unreasonably bright or causes unreasonable glare.

Change in exterior light fixtures does not require ARC approval if fixtures meet the rules and regulations above. An addition of a light post or change in previously approved light post in the front yard or in public view does require approval of the ARC.

EXTERIOR OF THE HOME

The exterior of the home is to include but is not limited to the roofs, siding, brick, stucco, color, windows, window frames, doors, light fixtures which are architectural components of the neighborhood that create a unifying element. Accordingly, no homeowner may alter or change the originally installed materials, location, or color without the written consent of the ARC. No prior approval is necessary to repaint the exterior of existing home using the most recently approved color scheme or to rebuild or restore any damaged structures in a manner consistent with the plans and specifications most recently approved for such structures. Generally, no approval is required for work done to the interior

of a home; however, modifications to the interior of porches, patios, and any other portions of a structure visible from outside of the structure do require prior written approval from the ARC.

FAÇADE EXTERIOR (Stone, brick, stucco siding, etc.)

Replacement of an existing façade with the same previously approved material does not require ARC approval. Replacement of an existing façade with a new façade material requires ARC approval.

FENCES

Type and location require ARC approval. See Fence Standards (pages 33-37) for specific fence requirements.

GATES

All gates must be approved by the ARC and match the architectural and materials outlined in fence standards with a maximum opening of thirty-nine inches (39”), the gate width shall be thirty-six inches (36”) and may use 4 x 4 cedar posts with black, self-closing hardware.

GAZEBOS

A gazebo is a detached, permanently mounted, decorative structure that is used as a seasonal gathering place. Gazebos must be approved by the ARC and need to adhere to the following guidelines:

- Shall match the colors and materials used on the home.
- Must be constructed entirely within allowable building setbacks as established by the Town.
- Cannot expand beyond 2% of the total square footage of the lot.
- Cannot exceed 10 feet in height.

GREENHOUSES

Permitted subject to ARC approval.

HOT TUBS

No hot tub shall be erected on any property without prior approval from the ARC. Hot tubs must be an integral part of the deck or patio area and are only permitted in the back yard of a home. Hot tubs must be setback at least 5-feet from all the property lines.

Hot tubs must be screened from public view and the location shall not create an unreasonable level of noise for the adjacent property owners. In some instances, additional plant materials shall be required around the hot tub area for screening purposes.

OUTBUILDINGS

Including by not limited to barns, garages, and studio spaces are permitted subject to ARC approval. Outbuildings must comply with municipal and building codes.

PAINTING (Exterior)

No homeowner may alter or change the original color or most recently approved color scheme without the written consent of the ARC. No prior approval is necessary to repaint the exterior of existing homes using the most recently approved color scheme. The ARC will apply the monotony rule of no home within two homes on either side or across the street can have the same color scheme. Exterior paint color schemes shall conform to the overall character of the neighborhood.

PATIOS

A patio is an exterior, at grade surface for gathering. Typical materials include concrete, gravel, paver stones or bricks. Enclosed patios are considered an addition/expansion and are covered in another section. All patios need to be approved by the ARC and located on the owner's lot. Patios that are located within 5-feet of the property lines shall be screened with plant materials for privacy purposes.

PAVING/PATHS/WALKWAYS

ARC approval is required for all walks, pathways, or other purposes and for all materials used, including concrete, brick, flagstone, steppingstones, or pavers. All paving, paths and walkways shall stay within the homeowner's property lines.

PET DOORS

Pet doors are only permitted to be installed at a ground level, back door that opens to an enclosed fenced area in the back yard. Pet doors are prohibited in the front of the individual home or above ground level.

PLAYGROUND STRUCTURES/SPORT COURTS

No playground structure or equipment shall be erected on any property without prior approval from the ARC. When proposing the play equipment location, consideration shall be given to adjacent properties so as not to create an undue disturbance. Play structures, swing sets and trampolines shall be placed a minimum of five feet (5') from all of the property lines in the rear yard. The play equipment height shall not exceed twelve feet (12') and play structures/equipment may be required to be screened with plant materials.

Sport courts may only be located in the rear yard. Sport court surfacing materials shall be industry standard material. No bright or intense court colors are permitted. Sport courts shall be located and used in accordance to not create an unreasonable level of noise. All sport courts must be setback at least five (5') from all the property lines. Owners may be required to install additional plant materials to screen sport courts from adjacent Lots. Temporary netting shall be reviewed on a case-by-case basis but if approved, it must be stored seasonally and kept well maintained.

PLAYHOUSES

Committee approval is required. Equipment shall be located in the rear or side yard. Size of play yards will be considered on a case-by-case basis depending on parcel size and proximity to neighbors. The maximum height of the equipment should not exceed ten (10) feet. In some cases, written consent from adjacent neighbors may be required.

POOLS

Permanent pools are permitted in the back yard of the home and must be approved by the ARC and the Town prior to installation. Temporary and above ground pools, beside kiddie pools, are permitted during Spring and Summer seasons and shall be stored through Fall and Winter seasons.

RAIN BARRELS

Rain barrels shall be located in the rear yard. The barrel material shall compliment the exterior of the house. The rain barrel shall not hinder the established drainage pattern and water flow of the lot.

ROOFING MATERIAL

Roofing materials refer to the shingles or tile material installed on a building rooftop. Replacement of an existing roof with the same previously approved material does not require ARC approval. Replacement of an existing roof with new roofing material or roof pattern or roof color requires ARC approval. All replacement roof shall coordinate with the exterior color and materials on the house.

SHED AND OUTBUILDING

ARC approval is required. Sheds shall be allowed only in rear yards. Sheds must be the same material and color as the exterior of the home, unless otherwise approved by the ARC. Sheds shall not be more than eight feet six inches (8'6") high at the peak, nor larger than 120 square feet. Siding, roofing, and trim material must match those on the home. The ARC, in reviewing the application for shed approval shall consider parcel grading, fence locations, landscape screenings, etc., in granting any approvals for a shed.

SKYLIGHTS

ARC approval is required. Small solar tube skylights are permitted but large bubble-type skylights are prohibited.

SOLAR PV SYSTEMS

Solar Photovoltaic (PV) Systems are used to absorb sunlight for electricity, or heat, as a component of a building's or home's overall energy system and a method of conserving energy. Homeowners are encouraged to incorporate energy conservation into their building/home systems, but any Solar PV System must be specifically approved by the ARC prior to installation and meet the guidelines below.

- All Solar PV Systems must be designed and installed by a professional licensed contractor. The Architectural Review Submittal needs to be accompanied by a plan that is "to scale" from the licensed contractor who will be installing the system with material and/or manufacture's description of system, photos/pictures of system and color of system.
- Mounting: A Solar PV Systems array can either be "flush mounted" or "tilt mounted". However, in order to integrate the Solar PV System into the architectural of the home, the Solar PV Systems array must be flush mounted, that is, match the existing plane of the roof (parallel to roof line), unless on a flat roof.
- If installed on a flat roof, the array may be tilted to allow proper exposure to the sun provided that a letter is provided to the Architectural Review Committee from the solar professional involved explaining the need for a tilt mounted array.
- Colors: Any component of the Solar PV System must integrate into the architecture of the home. The color of the Solar PV System components should generally conform to the color of the roof shingles to the extent practical (for instance, black frames on dark colored shingles, silver frames on light colored shingles). Solar "shingles" which mimic the look of a composite shingle are acceptable but should match the color of the current roof shingles as much as practical.
- Balance of Systems: Inverters and DC safety disconnects are typically mounted in the basement, garage, or near the electrical meter on the outside of a home. The safety disconnects are usually required by the local utility to be mounted next to the electrical meter. The Owner is required to obtain any Town permits and electrical inspections required in connection with the Solar PV System.
- Conduit should be installed near a drainpipe or other existing runs from the roof to hide the

conduit as much as possible. In the event that compliance to these guidelines causes financial burden, then the homeowner seeking approval for a variance due to financial burden shall provide a minimum of two bids depicting the cost of installation of the solar systems in compliance with this policy and one depicting the desired alternative method. Variances may be granted if compliance with these guidelines would significantly increase the purchase price or operating cost of the Solar PV System or significantly decrease its performance or efficiency.

TRASH BIN ENCLOSURES

Trash bin enclosures require approval and will be reviewed on a case-by-case basis. Trash bins must abut the side of the home, be located behind the wing fence or 10' from the front façade of the home and must be screened from view with a wood screen or masonry/brick wall that matches the house. The enclosures can be no taller than 6 inches higher than the trash receptacles and must be made of 3 sides including a gate which prohibits visibility of the containers and include a cover with matching roof material. The structure must be maintained or if not maintained, removed. The trash bins shall not be visible from the front yard or street.

VEGETABLE GARDENS

Vegetable gardens do not require approval if they are located in the rear or side yard. All gardens (in ground and raised boxes) shall be setback at least 5-feet from all property lines. All gardens must be kept weed free and well maintained. Landscape timbers, bricks or decorative concrete blocks are encouraged materials for raised garden beds.

WALLS (Stone, Brick, Stucco, Wood, Retaining, etc.)

Walls that were not part of the original vision and plan of the community can negatively affect the original grading and drainage and the overall aesthetic within the community. Accordingly, no owner shall alter, add, or change the walls throughout the community or in their individual yards without prior ARC approval. All proposed retaining walls shall be constructed with materials that coordinate with the exterior of the house and shall not alter the established drainage pattern of the lot.

WATER FEATURE (Ponds, Fountains, etc.)

It is important that all water features do not negatively affect the physical aesthetics or improvement or adversely affect grading or drainage. Water features are permitted within the individual single-family yards and need to adhere to the following guidelines and be approved by the ARC:

- Water features must use recycled water.
- Height – Cannot be higher than 4-feet including any spouting water.
- Width – water features cannot expand beyond 15% of the total square footage of the front or rear yard area.
- Should drought or water restrictions be enforced by the Town the Owner will need to follow all such restrictions regarding the running of their water feature.
- Underground water features will not exceed 2 feet in depth.
- All water features need to follow the established landscape Architectural guidelines, including all grading and drainage requirements.
- All water features must be located at a minimum of 5-feet from the foundation of the existing residence.

WINDOWS

Replacement of a window or window frame with the same previously approved material does not require ARC approval. Replacement of a window with a new window or window frame or location requires ARC approval.

YARD DECORATIONS, ORNAMENTS, SCULPTURES ETC.

All yard decorations, ornaments, sculptures, bird house and baths must be approved by the ARC. Yard ornaments that do not exceed five (5) feet in height and are not more than two (2) feet in width like bird houses or garden decorative stakes that are placed in the back yard may be acceptable. Excessive yard decoration may be reviewable by the ARC and/or Board if the ARC feels is unacceptable or receive complaints.

3.3 ARCHITECTURAL REVIEW COMMITTEE PROCEDURES

Per the Declaration, the Board of Director's may establish in its discretion from time to time an ARC for the District. In the absence of appointment of an ARC the Board will act as the ARC. The ARC shall consist of three (3) or more persons appointed by the Board of Directors and if Board elects not to appoint an ARC then the Board will act as the ARC until at which time an ARC is appointed by the Board, which persons may be directors; provided, however, that until all of the Lots That May Be Included have been conveyed to the first Owner thereof (other than Declarant or a Builder), Declarant may appoint the ARC in which case the ARC shall consist of at least one but not more than three persons as determined by Declarant. The power to "appoint," as provided herein, shall include without limitation the power to: constitute the initial membership of the ARC; appoint member(s) to the ARC on the occurrence of any vacancy therein, for whatever reason; and remove any member of the ARC, with or without cause, at any time, and appoint the successor thereof. Each such appointment may be made for such term(s) of office, subject to the aforesaid power of removal, as may be set from time to time in the discretion of the appointor.

The ARC will serve a term of two (2) years each, except the initial ARC which will serve the terms of one member one (1) year and two members (2) years.

The ARC will appoint a chairperson.

The ARC will meet on an as needed basis.

Per the Declaration, the ARC shall approve, approve with conditions or disapprove all requests for approval within forty-five (45) days after the complete submission of the plans, specifications and other materials and information which the Committee may require in conjunction therewith.

Per the Declaration, a majority vote of the ARC is required to approve a request for approval, unless the ARC has appointed a representative to act for it, in which case the decision of such representative shall control. If a representative acting on behalf of the ARC approves or denies a request for Architectural approval, any Owner shall have the right to an appeal of such decision to the full ARC, upon a request therefore submitted to the ARC within thirty (30) days after such approval or denial by the ARC's representative. Unless the Board of Directors is acting as the ARC, if the ARC approves or denies a request for Architectural approval (whether by original decision or an appeal) then, any Owner shall have the right to an appeal of such decision to the Board of Directors, upon a written request therefore submitted to the Board of Directors within thirty (30) days after such decision by the ARC.

The ARC shall have the right to disapprove any application which is not suitable or desired for aesthetic or other reasons.

The ARC will meet on an annual basis to evaluate and review process, submittal forms, guidelines and other organizational components of the Architectural Review process and submit any recommended changes or amendments to the Board of Directors for review and approval.

Records: Per the Declaration, ARC shall maintain written records of all applications submitted to it and all actions taken by it thereon and such records shall be available to property owners for inspection in accordance with the District’s governance policies.

Liability: Per the Declaration, neither the Board of Directors, nor the ARC, nor any members thereof, nor any representative of the ARC appointed to act on its behalf, shall be liable in damages to any Person, or to any Owner, by reason of any action, failure to act, approval, disapproval or failure to approve or disapprove in regard to any matter within its jurisdiction hereunder.

Variance: Per the Declaration, the ARC may grant reasonable variances or adjustments from any conditions and restrictions imposed by the Declaration, Rules and Regulations or Guidelines in order to overcome practical difficulties or prevent unnecessary hardships arising by reason of the application of any such conditions and restrictions.

Such variances or adjustments shall be granted only in case the granting thereof shall not be materially detrimental or injurious to the other property or Improvements in the Community and shall not militate against the general intent and purpose hereof.

Waivers; No Precedent: Per the Declaration, the approval or consent of the ARC or any representative thereof, to any application for Architectural approval shall not be deemed to constitute a waiver of any right to withhold or deny approval or consent by the ARC or any representative thereof as to any application or other matters whatsoever as to which approval or consent may subsequently or additionally be required. Nor shall any such approval or consent be deemed to constitute a precedent as to any other matter.

Inspections: The ARC may make periodic inspections of the Homes to ensure compliance with these Architectural Guidelines and any existing ARC approvals.

Amendments: The Guidelines may be amended by the Board of Directors or the ARC with Board approval. Amendments to the Guidelines shall apply prospectively only. They shall not require modifications to or removal of any structures previously approved once the approved construction or modification has begun. However, any new work on such structures must comply with the Guidelines as amended. There shall be no limitation on the scope of amendments to the Guidelines, and such amendments may eliminate requirements previously imposed or otherwise make the Guidelines less restrictive.

Certification of Compliance: Any Owner may request in writing that the Reviewer issue a certificate of compliance certifying that there are no known violations of this chapter or the Guidelines. The District shall either grant or deny such written request within thirty (30) days after receipt and may charge a reasonable administrative fee. Issuance of such a certificate shall prevent the District from taking enforcement action against an Owner for any condition known to the District on the date of such certificate.

4.0 LANDSCAPE STANDARDS:

4.1 PUBLIC / OPEN SPACE LANDSCAPE

The Granary Metropolitan District will be in charge of all public open spaces, sidewalks, and community trails. The District will maintain irrigation lines for common areas, be responsible for snow removal on trails in the defined common area, pool and maintenance thereof, common trash receptacle removal, insurance for the aforementioned items, maintenance of the fences constructed in the common area, as well as maintenance of monumentation signage.



Note: Image is conceptual and shown for illustrative purposes only. Land Use Plan is subject to change.

4.2 PRIVATE LANDSCAPE

1. The location of trees and shrubs must be carefully planned so that mature sizes do not interfere with fences, landscaping, or structures on adjacent lots.
2. Front yard landscaping should create a cohesive “flowing” relationship between adjacent lots.
3. Front yard and side yard landscaping along all streets shall extend to the back of curb, including within the street Right of Way behind curb line.
4. Trees, shrubs, and planting beds should blend together between adjacent lots for a pleasing streetscape.
5. Planting beds between adjacent lots should appear unified by using the same type of rock or wood mulch.
6. Avoid designs with formal plantings, hard edges, mow curbs, or other materials that delineate lot lines.
7. Landscaping adjacent to native open spaces should blend and harmonize with the natural landscape.
8. Retaining walls should be low, visually attractive, and made of natural materials to complement the architectural style of the home. They should generally blend with the masonry used on the home and should appear to be a “natural outcropping.”
9. Garages, parking areas, driveways, utility boxes, trash enclosures, pet enclosures, play equipment, gardens, pools, tennis courts, hot tubs, etc., shall be screened from adjoining residences and streets.
10. Final tree placement is subject to required setbacks from utilities, light poles, and signs. Refer to the Final Plat Landscape Plan for homebuilder approximate tree lawn tree placement.

4.2.1 GENERAL LANDSCAPE REQUIREMENTS

Individual lot landscaping will be provided by each homeowner, or the builder at the builder's discretion. Design shall be in accordance with the covenants of the community. One (1) tree per lot shall be required in the front yard, two (2) trees shall be required in the front yard of corner lots, one (1) within the front yard and one (1) in the side yard facing public R.O.W. A minimum of 30% of each single-family lot shall consist of drip irrigated shrub beds with low to medium water use plants.

Landscaping shall be installed as soon as weather permits, but in any event no later than 6 months after a Certificate of Occupancy is issued.

Buried sprinkler systems must be installed in front, side, and backyards. All plant material shall be irrigated.

Trees shall be a minimum 2" caliper and shrubs shall be a minimum 5 gallon container.

Turf shall be a high quality drought tolerant bluegrass or an approved drought tolerant fescue.



4.2.2 LANDSCAPE GUIDELINES

All landscaping needs to be approved by the ARC prior to installation and meet the following guidelines.

COMPLETION DATE

All landscaping, except as described below for the tree lawn (area between street and sidewalk), must be completed within 180 days after the date of closing if the closing occurs during the growing season – April 1 – October 1 in the same year – or during the next growing season if the closing occurs outside of this cycle.

DRAINAGE/GRADING

1. Per the Declaration, Article 3.16, each Owner shall maintain the grading upon the Owner's Lot, at the slope and pitch fixed by the final grading thereof, including landscaping and maintenance of the slopes. The District is entitled to take necessary actions to ensure proper drainage from the Lots and Common Elements. Each Owner and the District agree, for themselves and their successors and assigns, that they will not in any way interfere with the established drainage pattern over any real property which they have a duty to maintain, from adjoining or other real property. In the event that it is necessary or desirable to change the established drainage over any Lot or Common Elements which an Owner or the District has a duty to maintain, then the party responsible for the maintenance of such real property shall submit a plan to the Board for their review and approval. For purposes of this Section, "established drainage" is defined as the drainage that exists at the time final grading of a Lot is completed.
2. No Owner may install improvements or alter grading to adversely affect drainage on any Lot. No Owner may alter, obstruct, or obliterate any drainage swales, pans, easements, or channels located or installed on any Lot or Common Areas. Each Single Family owner shall maintain all gutters, downspouts and extensions within such Owner's Lot to ensure that the gutters and downspouts remain in the down position and are free and clear of all obstructions and debris and that the water flow from such gutters and downspouts is directed away from the foundation and/or slabs on any improvement.

LANDSCAPE MAINTENANCE

To maintain the environmental ethic of the Community, the following performance standards shall be followed by Owners with respect to maintenance of their residential landscaping:

1. Overspray or excess runoff of irrigation water shall be avoided.
2. Watering Hours: outside watering shall be limited to the hours of 6:00 p.m. to 10 a.m., except when necessary to establish new landscaping.
3. All landscapes shall be maintained to eliminate noxious weeds and hazards. Turf grass should generally be mowed to maintain a uniform appearance.

LOCAL STREET RIGHT-OF-WAY

The local street right-of-way landscaping, including irrigation, tree lawns and street trees, shall be installed and maintained by the individual adjacent owner. The owner shall be responsible for ensuring that all tree lawns are installed in accordance with the Town of Johnstown Standards and Specifications and as shown on the approved Site Development Plan. The tree lawn shall be installed with blue grass. The landscaping within the tree lawn shall be completed within six (6) months of the issuance of the certificate of occupancy for the home abutting the tree lawn.

LANDSCAPING - FRONT YARD

The minimum planting standards for a front yard is one (1) tree (2" Caliper) and 5-10 shrubs.* All shrubs shall be located in planting beds.

*Ornamental grasses and perennials may be substituted for shrubs at a rate of 3 grasses/perennials per one 5-gallon shrub.

LANDSCAPING - REAR YARD

All landscaping, except as described for Local Street Right-of-Way (area between street and sidewalk), must be completed within 180 days after the date of closing if the closing occurs during the growing season – April 1 – October 1 in the same year – or during the next growing season if the closing occurs outside of this cycle. Rear yard landscape plans are required to be submitted, reviewed, and approved by the Metropolitan District prior to installation. Rear yard landscape options include turf, planting beds, mulched areas and/or xeriscape designs. Irrigation is required to maintain the rear landscape as appropriate for materials installed.

LANDSCAPING - ARTIFICIAL TURF

Artificial turf may be considered in a side or rear yard but not in areas visible from public streets, subject to Colorado Law. Total artificial turf of any height may not exceed 50% of the total area of the lot that is landscaped.

The design intent is for artificial turf to emulate natural grass. Please state the intended use of the turf on the application. If selecting one of the pre-approved artificial turf brands listed below, please submit the manufacturer cut sheet or informational sheet with the application. If a pre-approved artificial turf is not being proposed, the application must include a physical sample of the proposed material showing the color and pile height.

Allowable Products

The color must be similar to the geographical area, preferably a blended, multi-color monofilament fiber. There are certain products that have been pre-approved by the ARC as meeting the requirements of these Guidelines. The pre-approved brands are listed below.

Allowable Products Continued

- Easy Turf – Ultimate Natural Artificial Turf 2" height.
- Easy Turf – Pedigree 1 1/2" height.
- Next 2 Natural – Natural Envy 2" height.
- Next 2 Natural – Sense 2" height.
- Mile High Synthetic Turf – Colorado Blend Pro 2" height.
- Mile High Synthetic Turf – Colorado Blend King 2 3/8" height.
- Purchase Green – Arizona Platinum Olive 2" height.
- Purchase Green – Arizona Platinum Spring 2" height.

Installation Considerations:

- Professional installation is required and must include a weed barrier and a porous, aggregate road base for drainage.
- Proper infill for residential application, such as a silica sand or “Envirofill” for kid and pet areas must be used. If only for a pet use area, a product with less secondary thatch may be used. Infill must not be toxic to humans or pets and must blend into the turf and not be visually distracting.
- The established drainage pattern may not be blocked or altered by the installation of artificial turf.
- A weed suppressor must be used under seams and the seams must be properly secured.
- If an artificial turf area will meet an area where native landscaping has been established, it must be separated by a barrier of at least four (4) inches of hardscape or planting area.

Maintenance Considerations

Artificial Turf must be cleaned as necessary and periodically groomed to maintain its appearance. The District reserves the right to inspect and require replacement after the life expectancy has been reached, typically 15 to 20 years, or if the turf is not maintained in good condition.

LANDSCAPING - XERIC WITH NO TURF

All xeric landscape plans must incorporate the installation of an automatic underground irrigation system to help maintain the plantings. Xeric landscape plans, for front or rear yards, that do not propose irrigated turf grass as a ground cover will be required to have living plants (shrubs, ornamental grasses or perennials) cover 50% of the front or rear yard landscape area upon the plants installation and 75% coverage of the landscape area after three years growth. Large expanses of exposed rock, without plant coverage, is not allowed. The use of a variety of mulch, ground cover types and evergreen plants are required to add year-round interest and color.

NOXIOUS PLANTS

The following is a list of plants considered to be invasive species and not to be planted at The Granary.

Perennials

Bouncing bet, soapwort Cypress spurge
 Dalmation toadflax, butter & eggs Dame’s rocket
 Mediterranean sage
 Myrtle spurge, Mercer’s spurge Ox-eye daisy
 Perennial sweet pea, perennial pea vine Purple loosestrife
 Scentless chamomile Sulfur cinquefoil
 Sweet clover, white & yellow

Grasses

Crested Wheatgrass
 Orchard grass Smooth brome
 Hungarian brome grass Timothy
 Shrubs Buckhorn Scotch Broom

Rock

Areas of gravel or river rock shall be restricted to the brown, gray, or Colorado sandstone color tones. Rock color ranges with natural looking stone that fits within the overall character of the community are permitted and encouraged.

4.2.3 XERISCAPE REQUIREMENTS

At time of publication of this document the Town of Johnstown does not have standards related to xeric design of landscapes. All Xeriscape design elements must follow the Seven Principles of Xeriscape.

1. All xeric landscape plans must incorporate the installation of an automatic underground irrigation system to help maintain the plantings.
2. Xeric landscape plans, for front or rear yards, that do not propose irrigated turf grass as a ground cover will be required to have living plants (shrubs, ornamental grasses or perennials) cover 50% of the front or rear yard landscape area upon the plant's installation and 75% coverage of the landscape area after three years growth.
3. Large expanses of exposed rock, without plant coverage, is not allowed.
4. The use of a variety of mulch types and evergreen plants are required in order to add year-round interest and color.

4.2.4 SYNTHETIC / ARTIFICIAL TURF REQUIREMENTS

Synthetic/Artificial Turf is permitted in back yards and side yards behind wing fences and privacy fences. Concrete or stone edging is required at all locations where the artificial turf is terminated. Synthetic/ Artificial Turf is not permitted in front yards, yards adjacent to Open Space or in accordance with Colorado Law. ARC approval is required.

1. The artificial grass product must be made of Polyethylene and have a minimum face weight of 50oz. with a permanent backing.
2. The color must be similar to the geographical area, preferably a blended, multi-color monofilament fiber with that and a minimum pile height of 1.5 inches.
3. Professional installation is required and must include a weed barrier and a properly prepared aggregate base for drainage. An infill system is required.
4. Artificial grass must be cleaned as necessary and periodically groomed to maintain its appearance.
5. Artificial grass products may be inspected annually after the expiration of the warranty period to ensure the aesthetic properties are maintained. The Board of Directors reserves the right to require replacement after the life expectancy has been reached.

The following must be submitted with the Application for Architectural Improvement

1. A sample of the product including model name and style (unless it is an Allowable Product as defined previously).
2. Complete product specification sheet from the manufacturer.
3. The manufacturer's warranty on the product being submitted.
4. Photo(s) of the area to be covered by the artificial grass.
5. Photo(s) of proximity areas as well as description of the method of installation.

4.3 LANDSCAPE LOT TYPICALS, MAINTENANCE, & REQUIRED PLANTINGS

4.3.1 SINGLE FAMILY DETACHED FRONT AND SIDE LOAD

INSTALLATION AND MAINTENANCE REQUIREMENTS

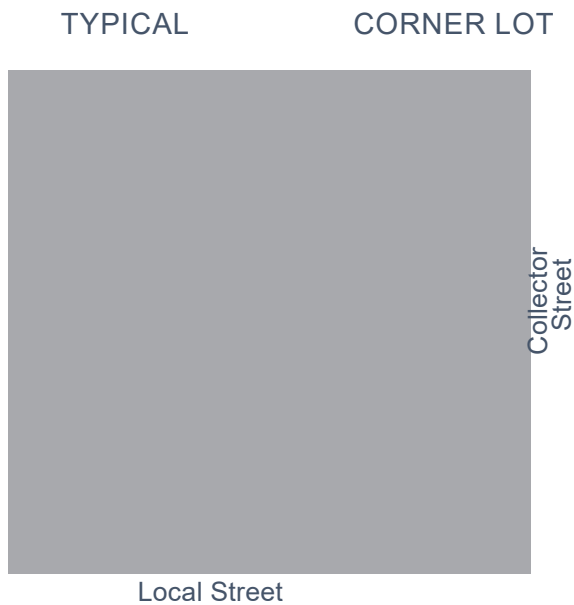
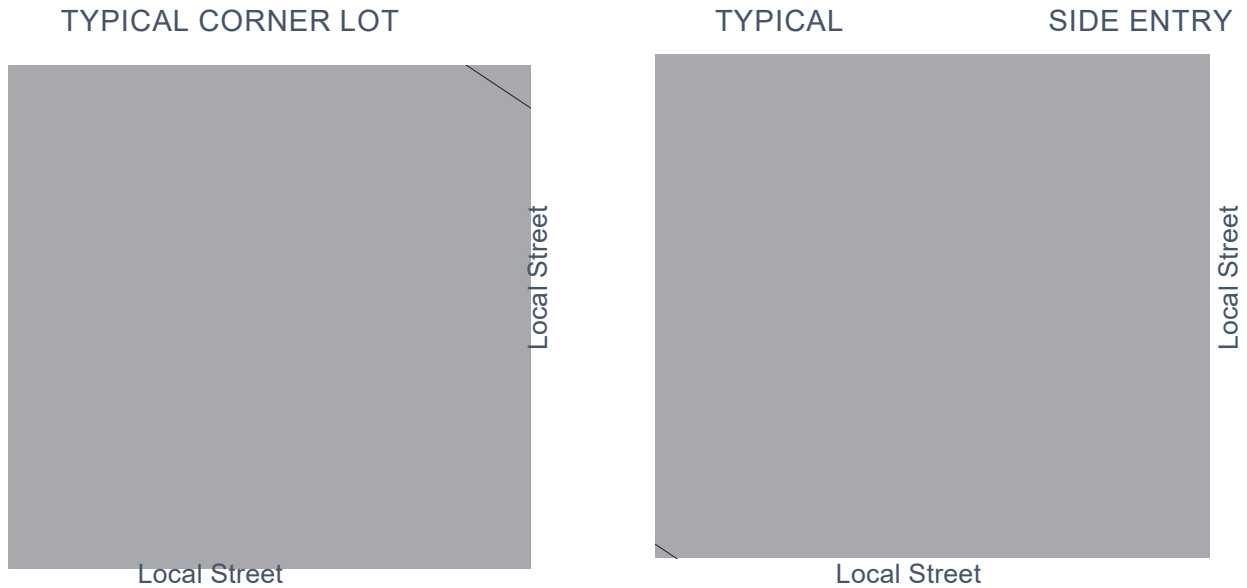

- Property Line
- 3-Rail Fencing
- Landscape installed by Builder and maintained by homeowner
- Landscaping installed by homeowner or builder and maintained by homeowner

REQUIRED PLANTING AND TYPICAL LOT PLANTING DESIGN

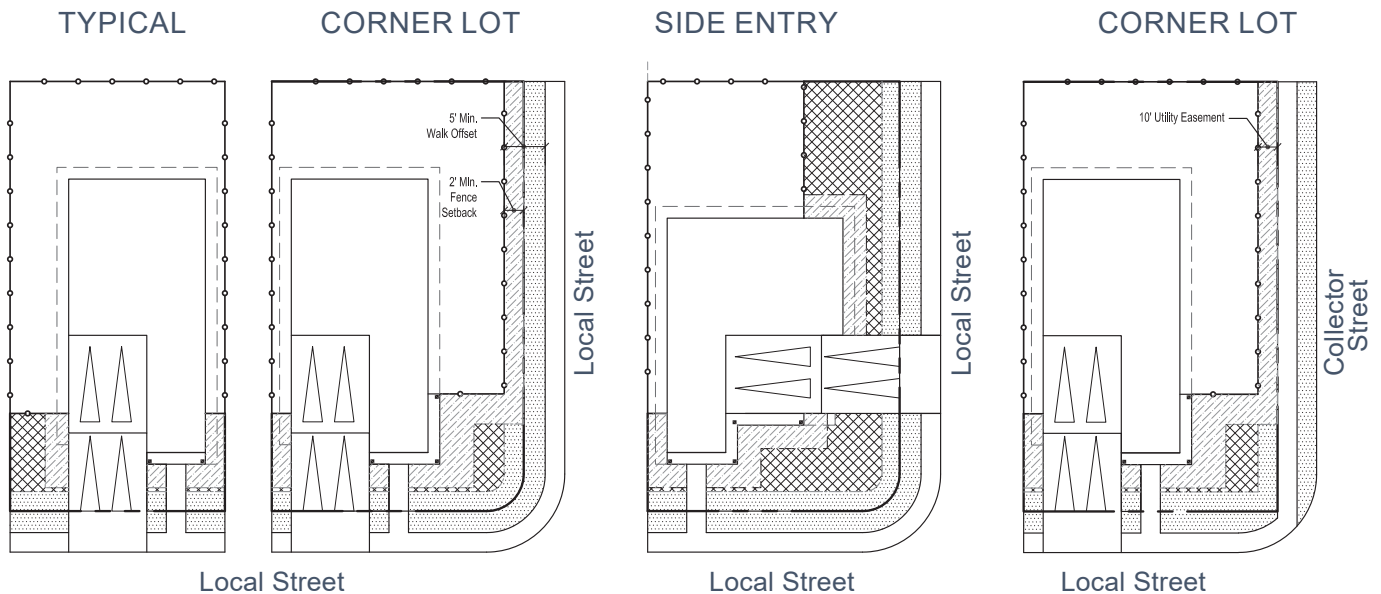

- Minimum Turf
- Flex Zone
- Minimum Planting Bed
- Property Line
- Fencing
- 3' No Irrigation Zone Line

Note:
 A 10' wide utility easement exists along all collector streets, measured from the public right of way/property line. In this condition, fencing (including post footers) must be placed entirely outside of easement to allow for unobstructed, long-term utility maintenance.

Minimum Required Quantities By Lot Type and Location					
Material	Typical Lot	Corner Lot		Side Entry	
	Front Yard	Front Yard	Side Yard	Front Yard	Side Yard
Ornamental Tree or Sm. Evergreen Tree	0*	1	0	0	0
Evergreen Shrubs	1	1	3	1	3
Deciduous Shrubs/ Ornamental Grasses/ Perennials	5	5	5	5	5

Notes:

1. Turf may have undulating form. Turf and bed line should meet adjacent home turf and bed lines when possible. The required five (5) foot wide turf and five (5) foot wide planting strip should be intermittently exceeded to provide planting variation. Where dimensions for five feet of turf and five feet of planting bed are less than ten (10) feet, plant only planting bed and no turf is permitted.
2. Maintain three (3) foot no irrigation zone around principal structure per geotechnical recommendations. Required five (5) foot planting bed does not include 3-foot no irrigation zone.
3. Flex zone allows homeowner to choose to expand either turf or planting bed areas.
4. Side yard incorporates area adjacent to side fencing and must meet a minimum of 80% coverage of live landscape material at least three (3) feet in height.
5. A diversity of plant types must be incorporated in all planting beds. No more than 25% of the same species of live shrubs, ornamental grasses, or perennials, shall be planted.
6. Variations from required planting may be approved by the ARC on an individual basis.

REQUIRED PLANTING AND TYPICAL LOT PLANTING DESIGN

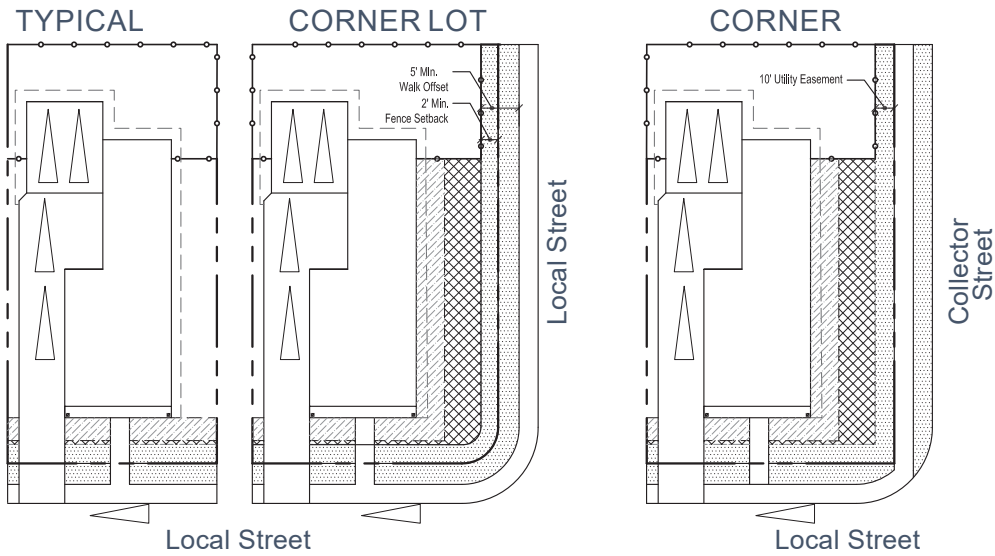

Note:
A 10' wide utility easement exists along all collector streets, measured from the public right of way/property line. In this condition, fencing (including post footers) must be placed entirely outside of easement to allow for unobstructed, long-term utility maintenance.

 Minimum Turf  Property Line
 Flex Zone  Fencing
 Minimum Planting Bed  3' No Irrigation Zone line

Minimum Required Quantities By Lot Type and Location

Material	Minimum Required Quantities By Lot Type and Location		
	Typical Lot	Corner Lot	
	Front Yard	Front Yard	Side Yard
Ornamental Tree or Sm. Evergreen Tree	0*	1	0
Evergreen Shrubs	1	1	3
Deciduous Shrubs/ Ornamental Grasses/ Perennials	5	5	5

Notes:

1. Turf may have undulating form. Turf and bed line should meet adjacent home turf and bed lines when possible. The required five (5) foot wide turf and five (5) foot wide planting strip should be intermittently exceeded to provide planting variation. Where dimensions for five feet of turf and five feet of planting bed are less than ten (10) feet, plant only planting bed and no turf.
2. Maintain three (3) foot no irrigation zone around principal structure per geotechnical recommendations. Required five (5) foot planting bed does not include 3-foot no irrigation zone.
3. Flex zone allows homeowner to choose to expand either turf or planting bed areas.
4. Side yard incorporates areas adjacent to side fencing and must meet a minimum of 80% coverage of live landscape material at least three (3) feet in height or approved xeriscape option.
5. A diversity of plant types must be incorporated in all planting beds. No more than 25% of the same species of live shrubs, ornamental grasses, or perennials, shall be planted.
6. Variations from required planting may be approved by the ARC on an individual basis.

4.4 THE GRANARY SIGNATURE PLANT LIST

A minimum of 50% of the species selected by the homeowner shall be made up of the Granary Signature Plants.

For proper plant growth, Colorado soils shall be amended with organic material. A minimum of four cubic yards of organic material shall be added to topsoil per 1,000 square feet of planting area. Organic material shall be aged compost; wood humus from soft, non-toxic trees. Proper amendments as specified will improve drainage and, as a result, conserve water. Plants will flourish and live longer, healthier lives. A soil analysis should be performed prior to planting for proper micro nutrient recommendations.

Common Name

Latin Name

Deciduous Trees

Green Mountain Sugar Maple	Acer saccharum 'Green Mountain' TM
Espresso Kentucky Coffee Tree	Gymnocladus dioica 'Espresso'
Redmond American Linden	Tilia americana 'Redmond'
Shademaster Honeylocust	Gleditsia triacanthos Inermis 'Shademaster'
Burr Oak	Quercus macrocarpa
Western Hackberry	Celtis occidentalis

Ornamental Trees

Flame Amur Maple	Acer Ginnala 'Flame'
American Plum	Prunus americana
Native Chokecherry	Prunus virginiana
Quercus gambelii	Gambel Oak

Evergreen Trees

Black Hills Spruce	Picea glauca 'Densata'
Ponderosa Pine	Pinus ponderosa
Bakeri Spruce	Picea pungens 'Bakeri'
Colorado Blue Spruce	Picea pungens
Rocky Mountain Juniper	Juniperus scopulorum

Evergreen Shrubs

Red Yucca	Hesperaloe parviflora
Sea Green Pfitzer Juniper	Juniperus x pfitzeriana 'Sea Green'
Panchito Manzanita	Arctostaphylos 'Panchito'
Mops Mugo Pine	Pinus mugo 'Mops'
Dwarf Pinon Pine	Pinus edulis

Large Deciduous Shrubs

Pussy Willow	Salix discolor
Tall Western Sagebrush	Artemisia tridentata
Saskatoon Serviceberry	Amelanchier alnifolia
Arctic Fire Dogwood	Cornus sericea 'Arctic Fire'

Common Name

Latin Name

Medium Deciduous Shrubs

Gro-Low Fragrant Sumac
 Pawnee Buttes Sandcherry
 Russian Sage
 Rabbitbrush
 Western Sand Cherry
 Apache Plume
 Spanish Gold Broom

Rhus aromatica 'Grow-Low'
 Prunus besseyi 'Pawnee Buttes'
 Provsia artiplicifolia
 Chrysothamnus nauseosus
 Prunus bessyi
 Fallugia paradoxa
 Cytisus purgans 'Spanish Gold'

Small Deciduous Shrubs

Mountain Ninebark
 Kelseyi Dogwood
 Littleleaf Mountain Mahogany
 Leadplant
 Fernbush
 Rock Spirea

Physocarpus monogynus
 Cornus sericea 'Kelseyi'
 Cercocarpus intricatus
 Amorpha canescens
 Chamaebatiaria millefolium
 Holodiscus dumosus

Ornamental Grasses

Blue Avena Grass
 Blonde Ambition Grama Grass
 Feather Reed Grass
 Indian Rice Grass
 Prairie Drop Seed
 Undaunted Muhly Grass
 Switch Grass

Helictotrichon sempervirens
 Bouteloua gracilis 'Blonde Ambition'
 Calamagrostis x Acutiflora 'Karl Foerster'
 Achnatherum hymenoides
 Sporobolus heterolepis
 Muhlenbergia reverchoni 'Undaunted'
 Panicum virgatum

Perennials

Magnus Coneflower
 Blanket Flower
 Double Bubble Mint Hyssop
 Husker Red Penstamon
 Crystal River Veronica
 Prairie Coneflower
 Moonshine Yarrow

Echinacea purpurea 'Magnus'
 Gaillardia aristata
 Agastache cana
 Penstamon digitalis 'Husker Red'
 Veronica 'Reavis Crystal River'
 Ratibida columnifera 'Red'
 Achillea 'Moonshine'

*Aspen tree varieties are not recommended due to their limited hardiness in this zone. Check with local nurseries for additional tree options that are well-suited for this region.

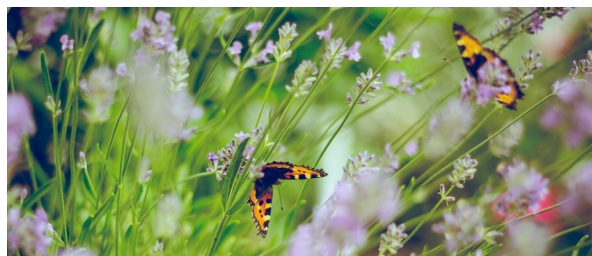
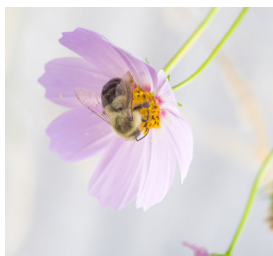
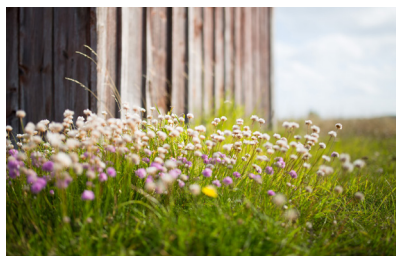

5.0 FENCING:

5.1 PERMITTED FENCING

Fencing at Granary is permitted along side and rear lot lines. Fencing is also permitted generally parallel to the front property line, set back a minimum of five (5) feet from the front plane of the home. Front yard fencing is not permitted. All fencing at Granary shall be the fences included in this document, unless otherwise approved by the ARC. The fencing shown below in ORANGE is to be installed by the Builder or Homeowner and is maintained by the Homeowner, and fencing shown in BLUE shall be built by the Developer and will be maintained by the Homeowner. The ARC may approve fencing designs similar in material and size to those included in this document.



- FENCING INSTALLED BY HOME BUILDER OR HOMEOWNER
 * MAINTAINED BY HOME OWNER

- FENCING INSTALLED BY DEVELOPER
 *MAINTAINED BY HOMEOWNER

5.1.1 FENCE TYPES

The details below and on the following pages depict the fencing types approved for use on properties adjacent to open space and on Single Family Detached Front-Loaded homes. Should different materials need to be utilized due to material availability constraints or other issues, alternate designs must be submitted to the ARC for review and cannot be installed without written approval.

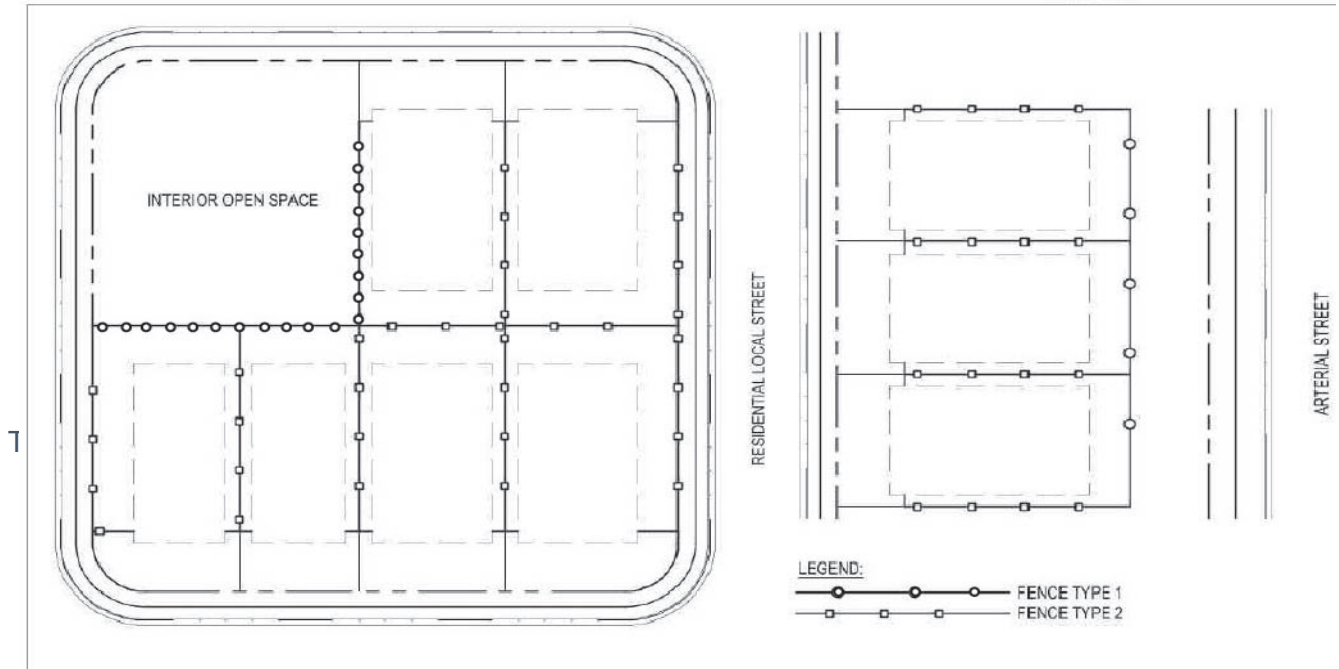

FENCE TYPE LOCATION DIAGRAM

Note:

For specific fence placement and required dimensional standards, refer to lot typical exhibits on pages 27 through 30 of these design guidelines.

FENCE TYPE 1 Privacy Fence (ALONG SINGLE-FAMILY SIDE LOT PROPERTY LINES OR AS APPORVED BY ARC.) *Not allowed along side yard abutting Roosevelt

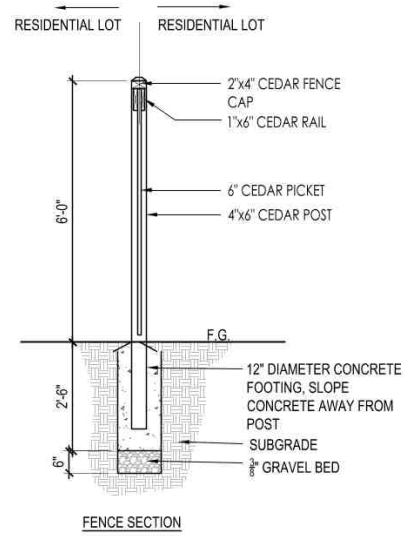
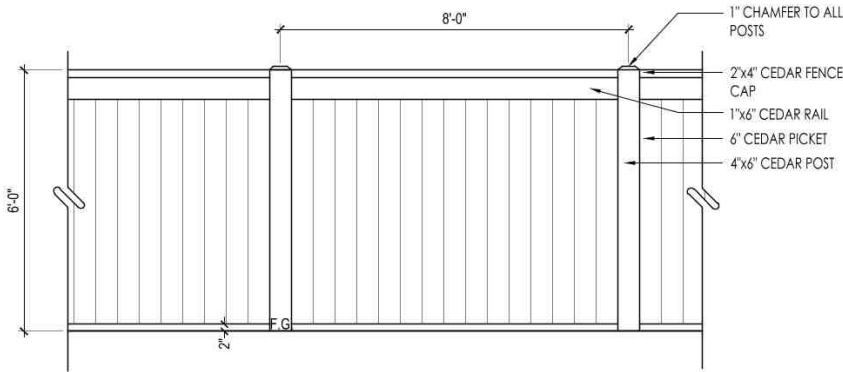

- NOTES:
1. FENCE TYPE 2 SHALL BE LOCATED AT ALL SINGLE-FAMILY LOT SIDE PROPERTY LINES.
 2. ALL FENCING MATERIALS SHALL BE CEDAR OR PRESSURE TREATED LUMBER #1 GRADE.

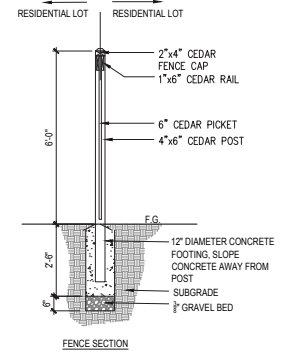
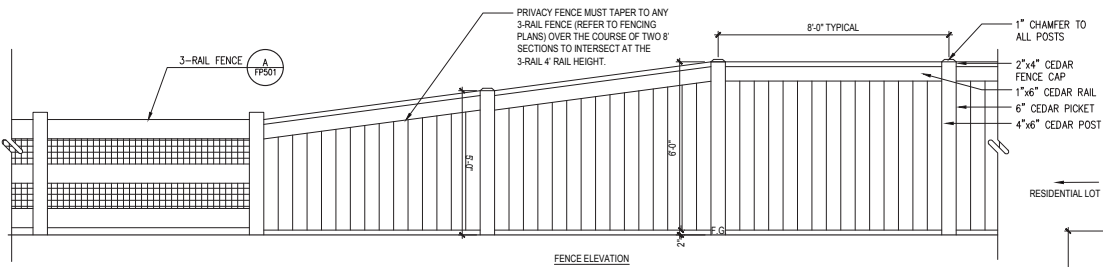

- NOTES:
1. REFER TO FENCING PLANS FOR LOCATIONS OF PRIVACY FENCE.
 2. PRIVACY FENCE MUST TAPER TO ANY 3-RAIL FENCE (REFER TO FENCING PLANS) OVER THE COURSE OF TWO 8' SECTIONS TO INTERSECT AT THE 3-RAIL 4' RAIL HEIGHT.
 3. ALL FENCING MATERIALS SHALL BE CEDAR OR PRESSURE TREATED LUMBER #1 GRADE.
 4. DEVELOPER'S STRUCTURAL ENGINEER TO APPROVE ALL COLUMN FOOTINGS.

RI (C) PRIVACY FENCE
SCALE: 1/2"=1'-0"

01 FENC 10/29/17

FENCE TYPE 2 (ALONG SINGLE-FAMILY LOT LINES THAT ARE ADJACENT TO INTERIOR OPEN SPACE)



TYPE 2 3-Rail: Inside Lot View



TYPE 2 3:Rail: Open Space View

Note: Homeowner or homebuilder can elect to install 12.5 GA welded wire mesh fencing. If welded wire mesh is desired, it must be installed on interior side of fence (facing lot interior) and adhered to 2x6" rail in a way that ensures long-term structural success of wire mesh.

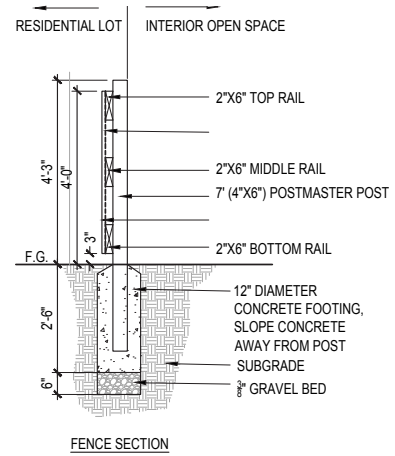
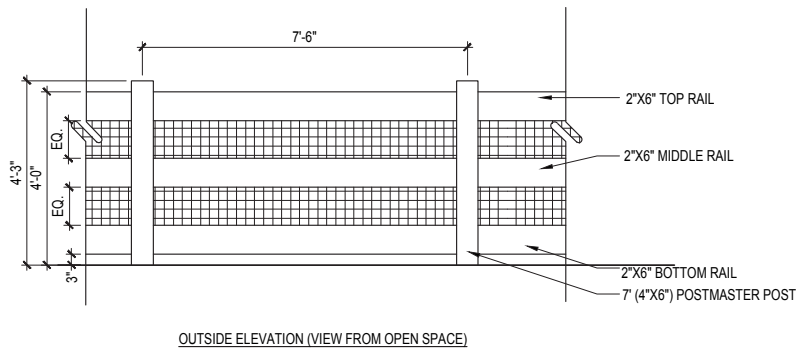

A 3 RAIL FENCE
SCALE: 1/2"=1'-0"

This page intentionally left blank

5.2 FENCING SETBACKS

1. Fences shall be set back from the front plane of the principal structure a minimum of five (5) feet.
2. Where feasible, fencing in side yards parallel to the front property line on adjacent lots should generally align in order to provide a consistent and uniform appearance.
3. Fences shall be set back five (5) feet from public sidewalks.

5.3 FENCING STANDARDS

1. All fencing materials shall be cedar or pressure treated lumber #1 Grade.
2. No front yard fencing is permitted.
3. Wing fences shall be set back a minimum five (5) feet from the front façade of house or garage.
4. Side yard fencing shall be 6' horizontal privacy fencing (type 2) and match the material and color of the rear yard property fence. All fences shall be placed on property lines and shall comply with municipal requirements. Side yard fencing on corner lots shall be set back a minimum of 2-feet from the side right-of-way line.
5. All fencing must be stained Sherwin Williams Super Deck SW2209 Tycoon Brown Solid Color Stain (also known as "The Granary Fence Stain").
6. Homeowners may choose to add wire mesh to open rail fences, material must be 2" x 2", 2" x 4", or 1 x 1 welded wire mesh. If 3-rail fence is existing, mesh may added by homeowner and shall be installed on the resident's side of the fence completely flat against all three rails from top to bottom. When Home Builder or Homeowner installs new 3-rail fences, mesh may be installed between posts and rails. All rails for 4' height 3-rail fencing shall be 2"x 6".
7. All rails for 6' height 4-rail fencing shall be 2"x 6".
8. All fence posts shall be 4"x 6".
9. Wire mesh shall be installed on the 6' height 4-rail fencing.

6.0 DEVELOPMENT AND BUILDER SIGNAGE:

6.1 SIGN LOCATIONS

No sign shall be erected in such a manner or location as to obstruct motorist, cyclist, or pedestrian vision, or obstruct the view of any traffic sign, signal or control device. All sign locations should be verified against approved The Granary subdivision plats and development plans to verify no utility conflicts. Should conflicts arise with any public utilities, utility locations will supersede sign locations and sign location or proportion will adjust accordingly. Verification of utility plans and field locates are required.

6.2 BUILDER SIGNS

Builder signs are temporary installations identifying individual home builders operating sales within the community. The list below identifies the types of signs that Builders may install. Builder signs shall conform to sign envelopes. Individual builders may include their corporate brand, font and logos on the Builder signs. Builder Signs will be located on Builder lots and sales areas. Developer reserves the right to determine if signage is consistent with the standards below. Developer must grant approval for any signs installed off Builder lots (within common areas). Once off-lot signs are authorized by Developer, Builder assumes all responsibility for damage to common area including irrigation lines. Builder Signs must be maintained in upright position and remain professionally displayed. Warn or leaning signs will be removed at Developer's discretion.

Allowed Builder Signage

1. Sales Office Sign

Builders are allowed one sales office sign per sales office location. This sign is intended to contain information such as builder name/logo, collection information, contact info, pricing info, etc. The sign may be designed to conform with the builder brand look & feel. Sign may not exceed 48 square feet. It is the responsibility of the builder to secure proper permits.

2. Model ID Sign

Builders are allowed one model ID sign per model home location. This sign may conform with the builder brand look & feel.

3. A-frame Sign

Builders are allowed up to two A-frame signs at their sales office location. A-frame signs may conform with the builder brand look & feel.

4. Bootleg/T-stake/Weekender Signage

Smaller, temporary signage such as bootlegs/t-stake/weekenders) are not allowed within the community. The exception to this rule is if temporary signs are directing visitors to a special event (ie. Parade of Homes, community programming, etc.). If that is the case, temporary signs may only be posted 24 hours in advance and throughout the duration of the event.

5. Feature/Selling Points Signage

Exterior signage declaring unique product selling points must be approved by Prairie Song's Development Company, Hartford Homes. This includes messaging such as energy efficiency, sustainability, safety and security call-outs.

6. Flag Poles

One flag pole is allowed per Sales Office to fly an American flag and a builder logo flag. Flag pole height may not exceed 50 feet. It is the responsibility of the builder to secure proper permits.

7. Lot/Block, Available, Sold and Private Residence Signs

Lot/Block, Available, Sold and Private Residence signs may conform with the builder brand look & feel.

8. Construction/Job Site Signage

Construction/Job Site Signs include information pertaining to builder job site guidelines/requirements. Signs may not exceed 32 square feet.

9. Promotional Signage

Promotional signage is considered to be temporary additions to a builder's sales office/model area to draw attention to a special promotion or event, ie. flutter flags, balloons, banners, etc.

Promotional items are permitted following these guidelines:

- a. Flutter flags, balloons and banners cannot create a nuisance.
- b. Flutter flags, balloons, banners and other indication signal materials can only be used during events, and must be taken down within two days after event completion. For example, if you're hosting an event all day Saturday, these materials must be removed by close of business on Monday.
- c. Temporary banners promoting special pricing or other incentives may be posted for a maximum of thirty (30) days.

10. Cloud Buster Balloons

A maximum of two cloud buster balloons are permitted per sales office location.

11. Off Site Signage

Any signage that is placed on property not owned by the Builder will need to be approved by Hartford Homes. Builders may pursue offsite signage with private landowners as desired or as allowed by the applicable municipality.

This page intentionally left blank.